



**Weblink**  
2536

Natural Wedge. Tokyo, Japan. Architect: Masaki Endoh + Masahiro Ikeda. Contractor: Ridea Construction Co., Ltd. Photo: Tetsuo Ishii, SS Tokyo

**Design**  
Arne Jacobsen

**Concept**  
AJ Wall creates direct and angled illumination. The lighting characteristics make it suitable when placed in a situation where distinct and directed illumination is required. The head can be rotated 60 degrees.

**Finish**  
Blue/green, yellow/green, petroleum, red or sand. Black, graphite grey or white, wet painted.

**Material**  
Shade: Spun steel. Base: Spun aluminum. Arm: Steel.

**Mounting**  
Switch: On/off switch located on the wallbox.

**Weight**  
Max. 6 lbs.

**Label**  
cULus, Dry or Damp location. IBEW.

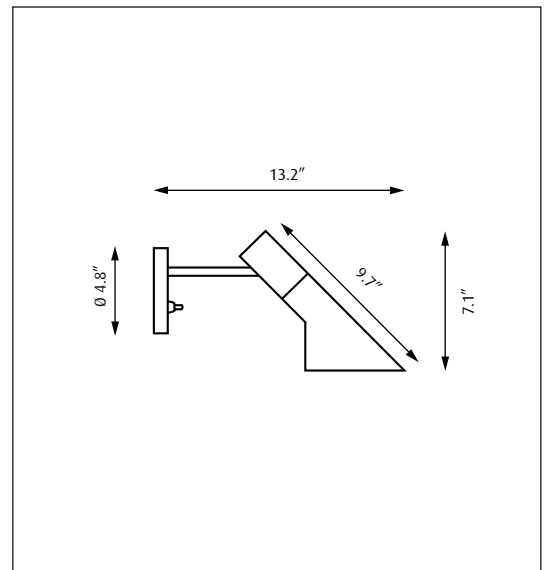

Prefix	Lightsource	Voltage	Finish
AJ-W	1/40W/G16.5/CAND	120V	BLK GRAPH GREY WHT BLUE/GREEN YELLOW/GREEN PETROLEUM RED SAND

Info notes:  
I. The comparable EU version has the following classification: Ingress Protection Code: IP20.

