



Model Specifications

Our Designer Range showcases our freestanding models, which are delivered fully assembled, ready to be placed where you wish, and are operational immediately. There are no installation or building works required. Ideal for apartment owners where space is limited, and very popular with tenants who would like ambient heating that moves when they do. Model includes Burner Kit, rear toughened glass panel and Wind Screen Static.

Applicable EcoSmart™ Burner	Standard models feature Burner One. UL Listed models feature Burner TwoUL. - please refer to applicable Model Specification.
Fuel	Use Denatured Ethanol only. Refer to www.ecosmartfire.com for commercially available fuel names around the world.
Design Features	The Vision is a rectangular shaped fireplace. It is a freestanding piece of furniture designed to accept the EcoSmart™ Burner. The EcoSmart™ Vision features a double opening with a “see-through” effect. The EcoSmart™ Fire Vision is designed for installation in units, apartments, houses, and commercial premises including offices, bars & restaurants.
Construction Detail	<p>SURROUND: Manufactured from MDF timber that is coated with a fire resistant two-pack solvent-borne top coat. The surround is constructed around a stainless steel firebox insert.</p> <p>FIREBOX INSERT: Firebox 900DB (part of the Renovator Range) is specifically designed to accept the EcoSmart™ Burner in the Vision setting. Made of brushed Stainless Steel. It includes four (4) fixing points on the facade to accommodate the installation of a wind screen.-</p> <p>WIND SCREEN: A Wind Screen Static is included with the model, this is fixed to the front of the Firebox via the four (4) fixing points on the facade. If a wind screen is not required, the model includes four (4) stainless steel plugs to hide these fixing points. - UL Listed models require the Wind Screen to be fixed at all times.</p> <p>BURNER: Placement and clearance allocated for one (1) EcoSmart™ Burner only.</p> <p>REAR: The rear of the Vision features a glass panel that closes the back opening without changing the transparency of the design. This is to reinforce the safety of the design. The glass panel is a piece of 8mm [0.315in] toughened Starfire® (low iron) glass. This type of safety glass is designed to withstand high temperature variations and has been tested for accidental touch.</p> <p>SKIRTING: Recessed black skirting all around the base.</p> <p>FEET: Four (4) nylon feet are pinned under the fireplace for ease of move and to prevent floor scratching. These can be removed for flush settings when required.</p>
Ventilation	<p>EcoSmart™ Fires do not require any form of permanent fixture or fitting, such as a flue for ventilation, a permanent gas connection or any kind of fixed utility for fuel supply.</p> <p>In a house of typical construction, that is, one that is not of unusually tight construction due to heavy insulation and tight seals against air infiltration, an adequate supply of air for combustion and ventilation is provided through infiltration. However, if the heater is used in a small room where less than 5.7m³ [200ft³] of air space is provided for each 1000 BTU per hour of heater rating (considering the maximum burner adjustment), the door(s) to adjacent room(s) should be kept open or a window to the outside should be opened at least 25.4mm [1in] to guard against potential build up of indoor air pollution. Do not install or operate in a bathroom or any other small room.</p> <p>Burner One: The room cannot be less than 70m³ [2472ft³] per burner. Burner Two: The room cannot be less than 25m³ [1000ft³] per burner.</p>
Recommended Accessories	Fire Extinguisher, EcoSmart™ Fire Screen or alternative Wind Screen.
Important!	Do not remove the back glass panel as natural air flow in the room could create a draft and make the flame breach out of the fireplace. The glass used in the EcoSmart™ Fire Vision is toughened glass which means it is stronger than normal glass and can withstand high temperature variations. Importantly, even though it is stronger, toughened glass still has weaknesses. The corners and sides are specific pressure points where it is more fragile and can break if care is not taken. In the case of breakage, toughened glass will shatter into small crystal-like pieces which can cause potential injury and be a choking hazard for small children. We advise that the glass should be handled with special care and that operation of the product should cease immediately if a fault is found. Breakage due to mishandling is not covered by warranty.
Compulsory Cross Reference	Please ensure you read the applicable Model Specifications for the EcoSmart™ Burner that is used in this model before ordering, specifying, installing or operating the EcoSmart™ Burner.

Model Specifications

Clearances

The Vision is designed as a room divider but can also be placed against any flat wall surface made out of non-combustible material or sitting 100mm [3.95in] away from any wall of any material. The glass side is the back in all circumstances.

Use common sense to ensure that your fire is positioned away from curtains, flammable materials and other sources of ignition. Be aware of drafts.

Installation Requirements

The Vision is designed to be positioned as a room divider or centrepiece within a room.

In all cases the EcoSmart™ Fire should:

- Be positioned in a large and open room that is centrally located in the house in order to optimize heat circulation
- Be positioned on a level floor – the floor can be made of any material or fabric
- Be positioned so that they adhere to the specific clearances of the model purchased
- Be fixed into a secure and permanent position prior to being operated, following the instructions below

Note: The Vision is heavy - you will need two (2) people to perform this procedure.

Equipment required: pencil, phillips head screw driver, drill.

1. Underneath the Vision there is a removable locking base, to access it, remove the nylon feet, locate and remove the plugs and screws found on all sides of the skirting;
2. Confirm that you have received all necessary fixings as illustrated;
3. Lift the Vision up and away;
4. Position the removed locking base into the desired location in accordance with the compulsory minimum clearances outlined in the Instruction Manual and mark the pre-drilled holes with a pencil (ensure clearances are for the entire model, not just the locking base);
5. Remove the locking base and drill holes in the centre of the positions marked; Using the screws supplied (A for Timber, B for Concrete), fix the locking base into position;
6. Position the Vision over the secured locking base and lower so it locks into position.
7. Screw the Vision and the locking base back together by replacing the screws and plugs removed in step 1 (do not replace the nylon feet).

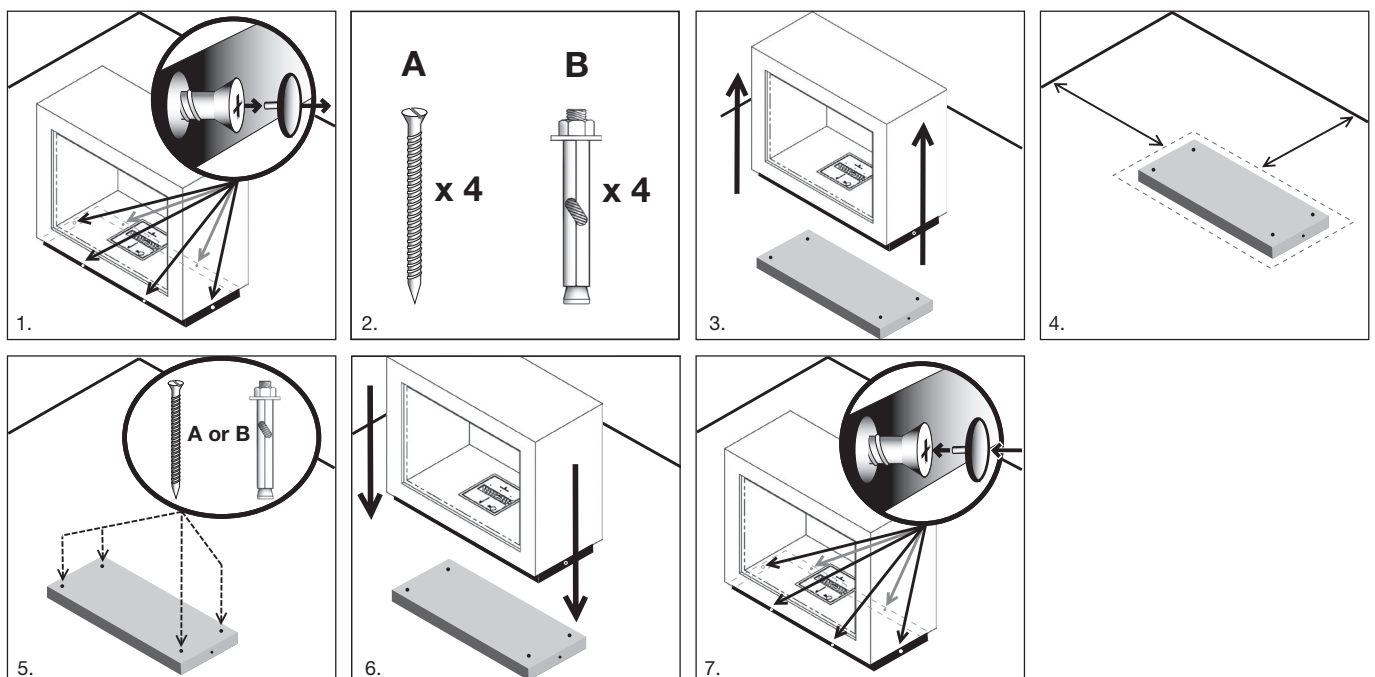

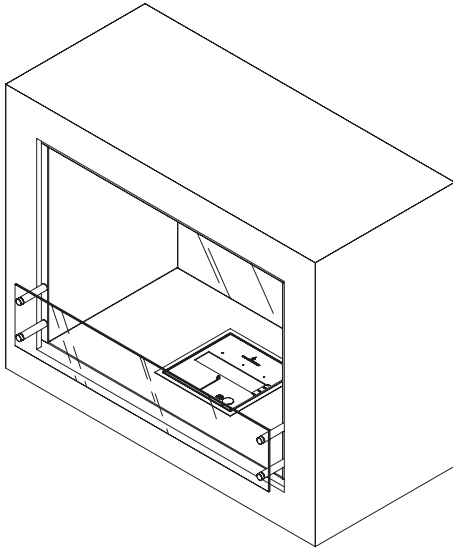

ISOMETRIC VIEW

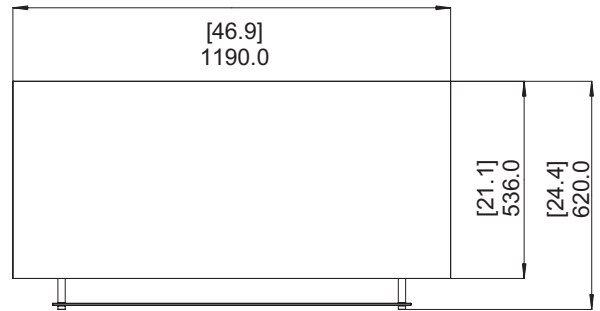

TOP VIEW

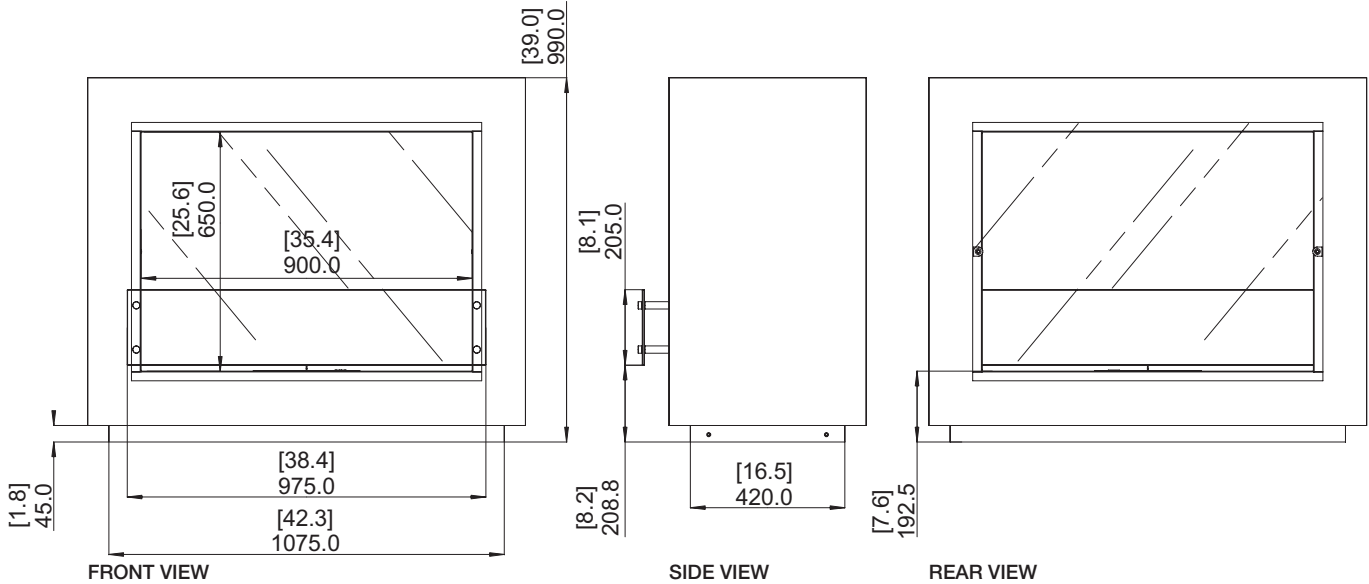

FRONT VIEW

SIDE VIEW

REAR VIEW

Measurements

[inches] = imperial
mm = metric

Weight, including packaging

127kg, 279.99lbs

Materials

Brushed Stainless Steel,
Toughened Glass, MDF

Scale 1:20



Conditions of Use

1. For the purposes of this model specification we refer to the fuel used in the EcoSmart™ Fire as **Denatured Ethanol***.

*There are many different names for this fuel around the world. Please refer to www.ecosmartfire.com for a list of commercially available fuel names in your country.

Denatured Ethanol* is classified as a Dangerous Goods Flammable Liquid Class 3, PGII and is regulated by specific standards and rules. You must familiarise yourself with the appropriate regulations of

your country in order to safely and legally store, handle, decant and use this fuel.

The customer warrants to The Fire Company Pty Ltd that after delivery of their EcoSmart™ Fire and whilst The Fire Company Pty Ltd retains any interest in the goods or consigned goods (as the case may be) the customer shall comply with all applicable Acts, Regulations and Laws dealing with the transport, unloading and storage of Dangerous Goods.

2. Children do not recognize the dangers that can arise when handling Dangerous Goods,

nor do they recognize the volatility of flammable liquids when ignited. Please ensure you keep children at a safe distance and supervised at all times when operating the fire.

3. Approval from building authorities may be required. Please ensure you contact the appropriate parties before installing your EcoSmart™ Fire.

4. It is a condition of purchase that you obtain a fire extinguisher Ammonium Phosphate AB:E type. These can be purchased from your distributor or independently.

Warnings

1. Risk of explosion:

- a) Never use any fuel other than the fuels specifically identified for use in the appliance. Never use gasoline.
- b) Never fill the fuel reservoir when it is operating or still hot.
- c) Never fill fuel reservoir in areas where flammable vapours or gas may be present.
- d) Never store or transport the fuel in other than a metal or plastic container that is:
 1. Acceptable for use with the specific fuel.
 2. Is in the original container for the alcohol fuel.

2. Never store fuel in the living space where the fire is situated.

3. Due to high surface temperatures, keep children, pets, clothing, and furniture away. The unit is hot while in operation, contact with the EcoSmart™ Fire may cause skin burns.

4. Risk of indoor air pollution – use EcoSmart™ Fires only in well-ventilated areas. People with breathing problems should consult a physician before using the appliance.

5. Do not use the EcoSmart™ Fire to heat or boil water or as a cooking appliance. Do

not throw waste materials or paper into the EcoSmart™ Fire.

6. EcoSmart™ Fires have not been tested with an unvented gas log set. To reduce the risk of fire or injury, do not install an unvented gas log set into this appliance.

7. The EcoSmart™ Fire has not been tested for use with doors. To reduce the risk of fire or injury, do not install doors.

8. It is recommended that the EcoSmart™ Fire be fixed into position to avoid displacement as per instruction provided with each model.

9. Do not dismantle the EcoSmart™ Burner.

10. Do not attach any other tank to the EcoSmart™ Burner.

11. EcoSmart™ Fires must only be operated using authorised accessories & equipment.

12. Do not obstruct the open/close sliding mechanism of the EcoSmart™ Burner in any way as this could result in the jamming/non functionality of the shut off mechanism.

13. The EcoSmart™ Burner should not be started if a fault is suspected or when there appears to be any damage to the burner or its housing.

14. The use of any fitting other than those available from or recommended by The Fire Company Pty Ltd for the EcoSmart™ Firebox and Burner is not permitted.

15. The Fire Company Pty Ltd does not accept responsibility for any damage which occurs if the EcoSmart™ Fire is used for purposes other than those for which it is intended, or if it is incorrectly operated or repaired by unqualified persons.

16. The EcoSmart™ Fire is not intended to operate continuously. To avoid heat expansion and potential splitting of the timber framework in Designer Range models please ensure that the model is allowed to cool down completely on a regular basis.

If you have any questions regarding any of the above important safety information please contact your distributor or The Fire Company Pty Ltd.

Testing & Compliance

The EcoSmart™ Fire Collection has achieved the following certification and approvals:



The EcoSmart™ Fire is manufactured by The Fire Company Pty Ltd whose quality management system is certified as being in conformity with ISO 9001:2000.



The EcoSmart™ Fire is the first product of its kind to have its collection so comprehensively UL/ULC listed. For the most up to date list of UL/ULC Listed models and compliance requirements please contact your local distributor.

Instructions and specifications for the EcoSmart™ Fire were tested as far as practicable to a selection of clauses from AS4553/AG103 – Australian Standard for Gas Space Heaters (closest comparable product at the time of invention)

Investigation into applicable standards and testing platforms for compliance to GS, CE & TUV were held and The Fire Company has gained a Compliance Verification Declaration from Globalnorm GmbH.



The EcoSmart™ Fire Collection has achieved Swedish Institute for Technical Approval in Construction (SITAC) approval.