

T

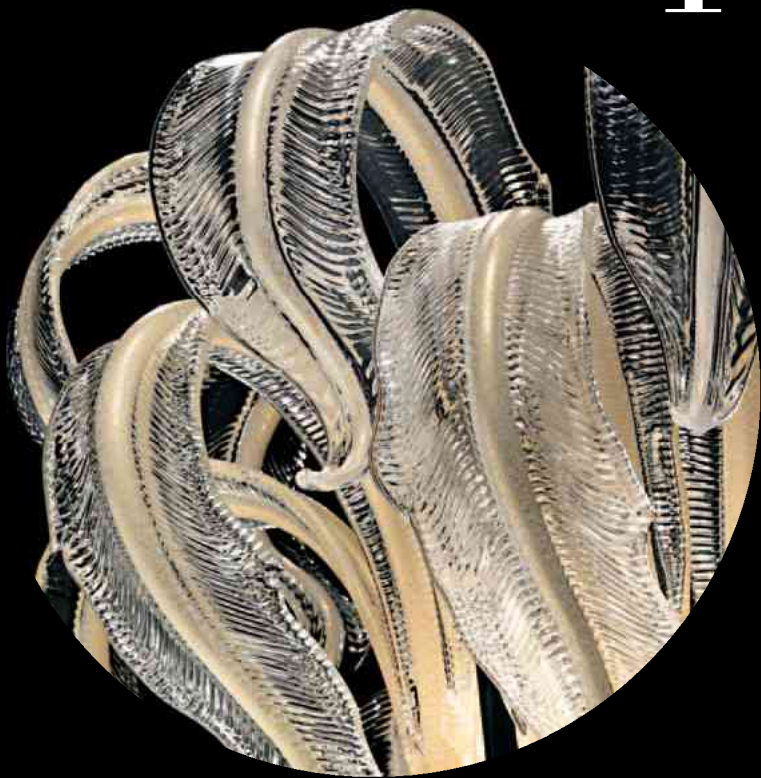

Barovier&Toso®

# T

come tradizione, come talento, come tema e variazione  
like tradition, like talent, like timeless

Barovier&Toso: il vetro di Murano e la sua cultura. Un fatto del tempo, più di settecento anni, un fatto del nome, due famiglie che lavorano già nel rinascimento, un fatto unico nel suo genere. Il vetro non è vetro, quando si alleggerisce, si addolcisce d'aria, si gonfia di colore e prende la luce: da quel momento, dalle tecniche dell'artigiano che lo ha scoperto, è vetro di Murano, vetro di Barovier&Toso. E il vetro di Murano, con la sua cultura e la sua tradizione, si impone come protagonista di forme, come veicolo di luce. Vetro e luce si sovrappongono, si fondono, si dispiegano in processi di illuminazione piena o totale. La fusione è armoniosa, e raggiunge una dimensione ottimale, avvalorata dal segno dell'esperienza di sempre e dalle idee innovative di importanti designer. Settecento anni di storia, il vetro di Murano, il design d'autore: una perfetta integrazione che dà vita alle collezioni Barovier&Toso.

Barovier&Toso means Murano glass and its history. It means time, more than 700 years, and it means name, that of two families who were already working together during the Renaissance. It means something that is unique of its kind. A gentle breath of air, a touch of color and glass is no longer just glass. During its making, it transmutes into a lighter substance, it takes on new dimensions. From that moment, the ingenuity of the craftsmanship that goes into its creation identifies the glass as that of Barovier&Toso. Murano glass, with its culture and tradition, is an established leader of forms as vehicles of light. Glass and light mingle, merge and unfold into processes of full, total illumination. This harmonious fusion has attained a pitch of excellence backed by the style and experience of centuries and by the innovative ideas of famous designers. Seven centuries of history, Murano glass, designers: a perfect integration generating Barovier&Toso's collections.

Barovier&Toso®



Grand Hotel	4
Felci	8
Spade	12
Palmette	16
Palace	20
Rex	24
Royal	28
Excelsior	32
Piume	36
Sospensione 1939	40
Fanali Veneziani	42
Rigati	48
Epoca	52
4868	56
5109	
5500	
Vortice	60
Plissé	62
Titanic	66
Fontana	70
Fanale 1930	74
Primavera	78
Impero	82
Note tecniche	86
<a href="#">technical notes</a>	

# Grand Hotel

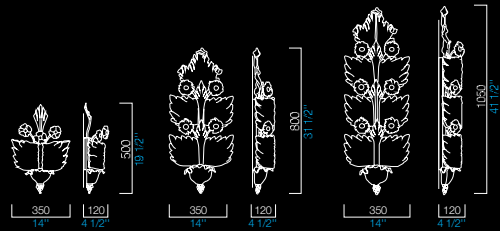

4662/2

4662/4

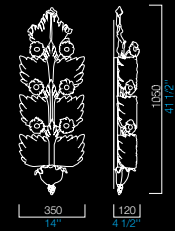

4662/6

5116/80



5116/60

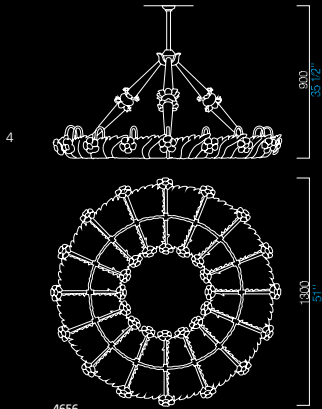

4656

CR  
cristallo rugiada  
crystal "rugiada"

OR  
rugiada oro  
golden "rugiada"





# Felci

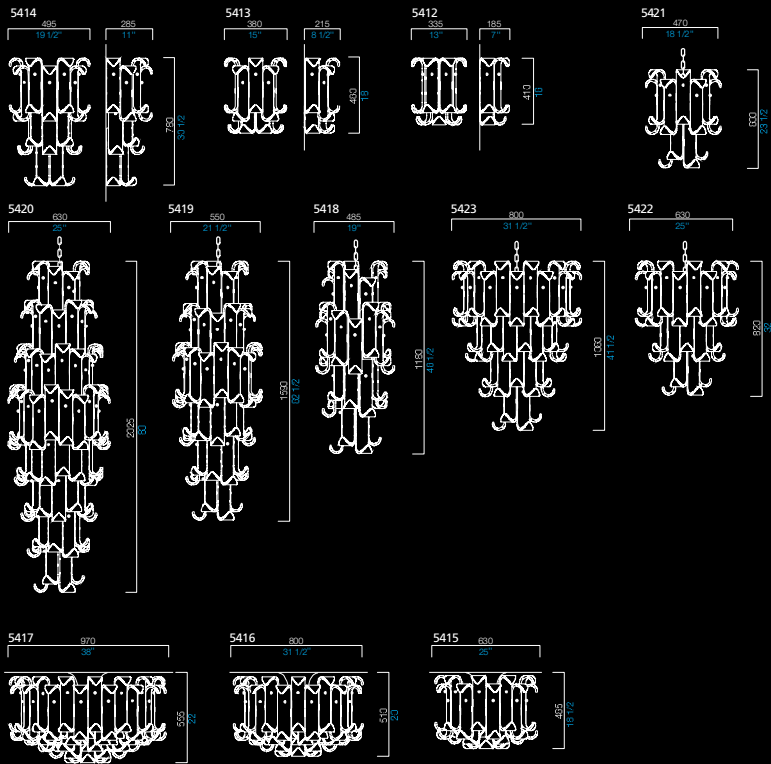

8

CC  
cristallo  
crystal





# Spade

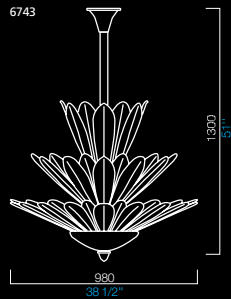
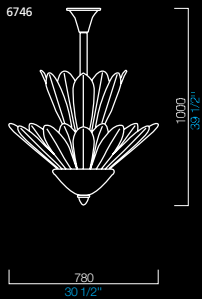
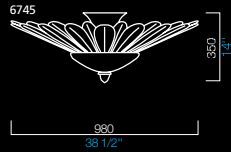
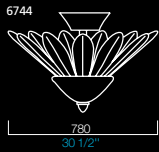
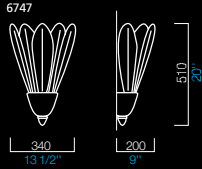

BB  
bianco  
white







# Palmette

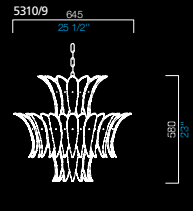
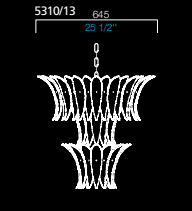
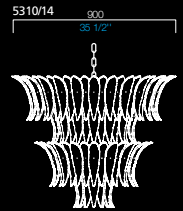
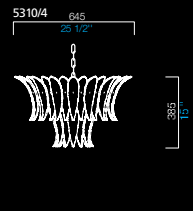
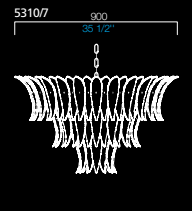
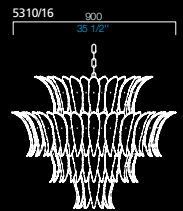
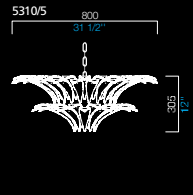
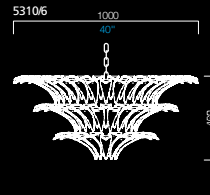
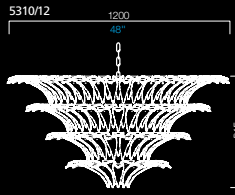
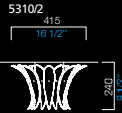

16

CC  
cristallo  
crystal





# Palace

5369



5368

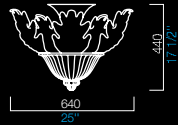

5367



5366



20



CR  
rugiada champagne  
champagne "rugiada"

CR  
cristallo rugiada  
crystal "rugiada"

OR  
rugiada oro  
golden "rugiada"





Rex

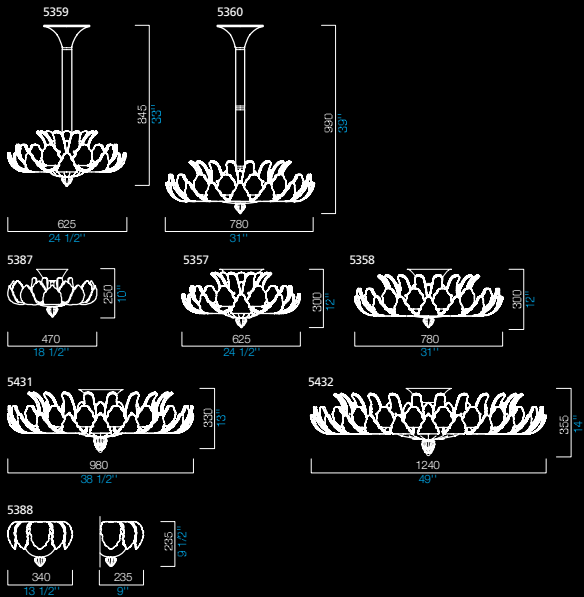

CR  
rugiada champagne  
champagne "rugiada"

CR  
cristallo rugiada  
crystal "rugiada"

OR  
rugiada oro  
golden "rugiada"





# Royal

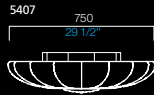
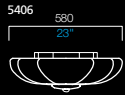

210  
8 1/2

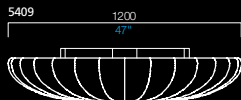
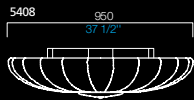
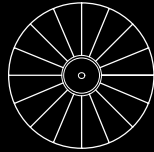
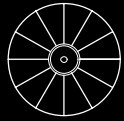

310  
12

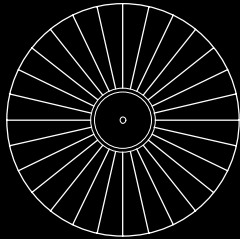
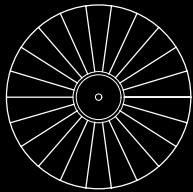

28

CR  
cristallo rugiada  
crystal "rugiada"

GR  
rugiada champagne  
champagne "rugiada"





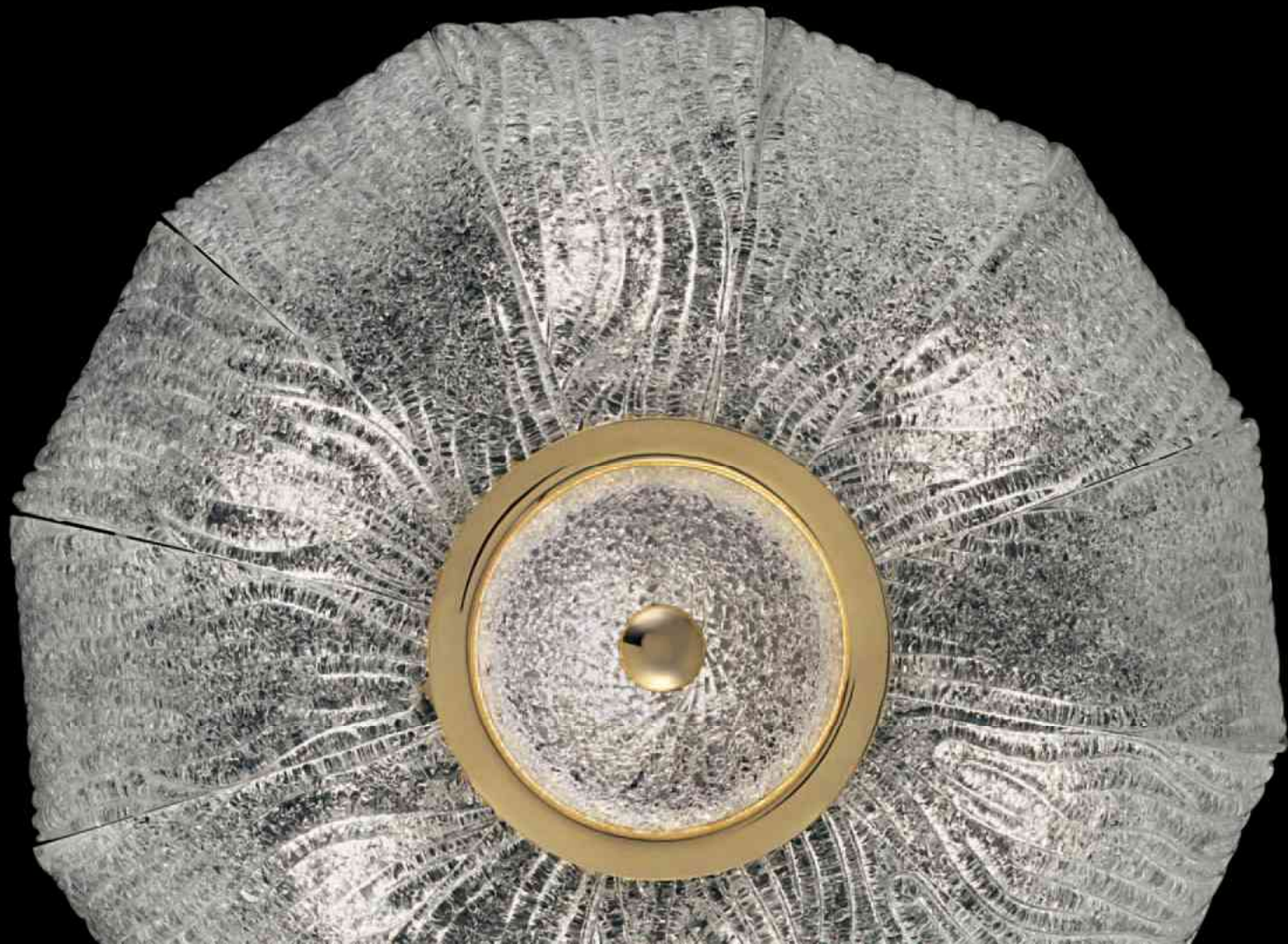

# Excelsior

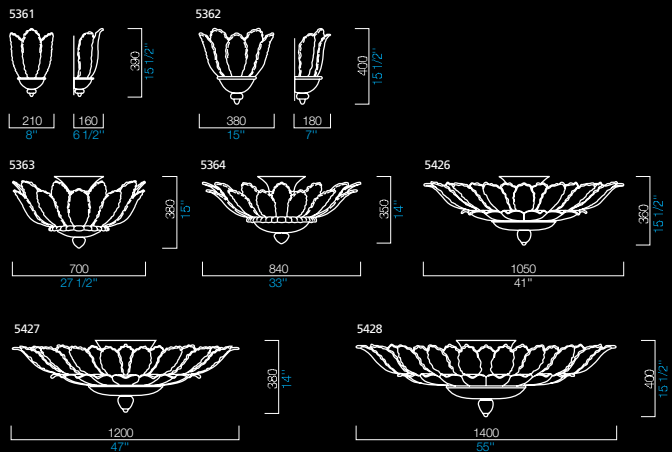

32

CR  
rugiada champagne  
champagne "rugiada"

CR  
cristallo rugiada  
crystal "rugiada"

OR  
rugiada oro  
golden "rugiada"





# Piume

5390



5391



5392

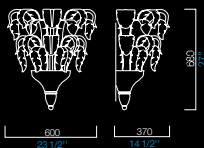

5393



5394



5395

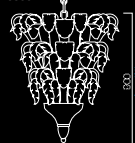

5396

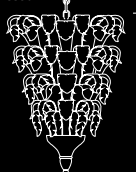

5397

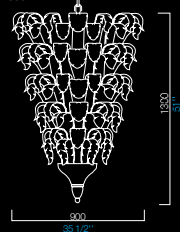

36

5399

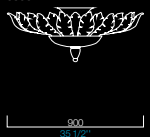

5400

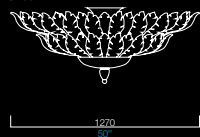

5401

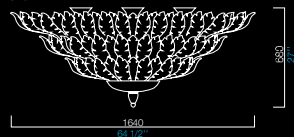

OB  
beige oro  
beige gold

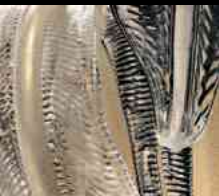



## Sospensione 1939



40

BB  
bianco  
white

VV  
verdino  
pale green



# Fanali veneziani

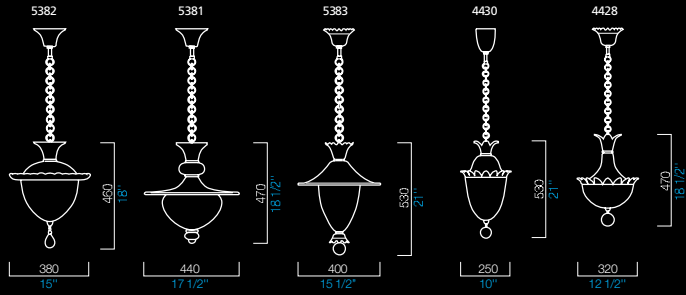

DO  
cristallo decoro oro  
crystal gold decoration

OB  
beige oro  
beige gold

OO  
oro  
gold









# Rigati

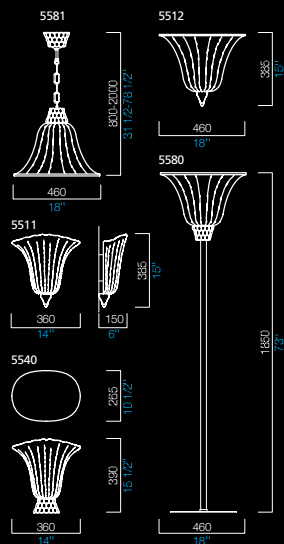

48

CG  
cristallo  
crystal

CG  
cognac  
cognac





# Epoca

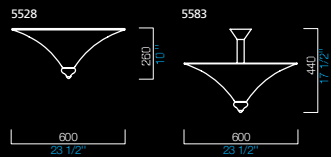

52



OB  
beige oro  
beige gold

PO  
perlaceo oro  
pearly gold

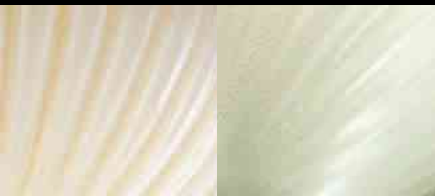



4868  
5109  
5500

4869



160  
6 1/2"

95  
3 7/8"

4868



200  
8"

120  
5"

320  
12 7/8"

5109/20



230  
9"

115  
4 1/2"

230  
9"

5109/27



280  
11"

140  
5 1/2"

285  
10 1/2"

5500



190  
7 1/2"

115  
4 1/2"

310  
12"

56

CR  
cristallo rugiada  
crystal "rugiada"



OB  
beige oro  
beige gold

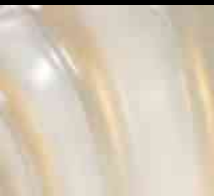

OR  
rugiada oro  
golden "rugiada"





# Vortice

5355/00



5355/85

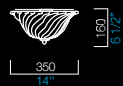

60



CR  
cristallo rugiada  
crystal "rugiada"



OR  
rugiada oro  
golden "rugiada"





# Plissé

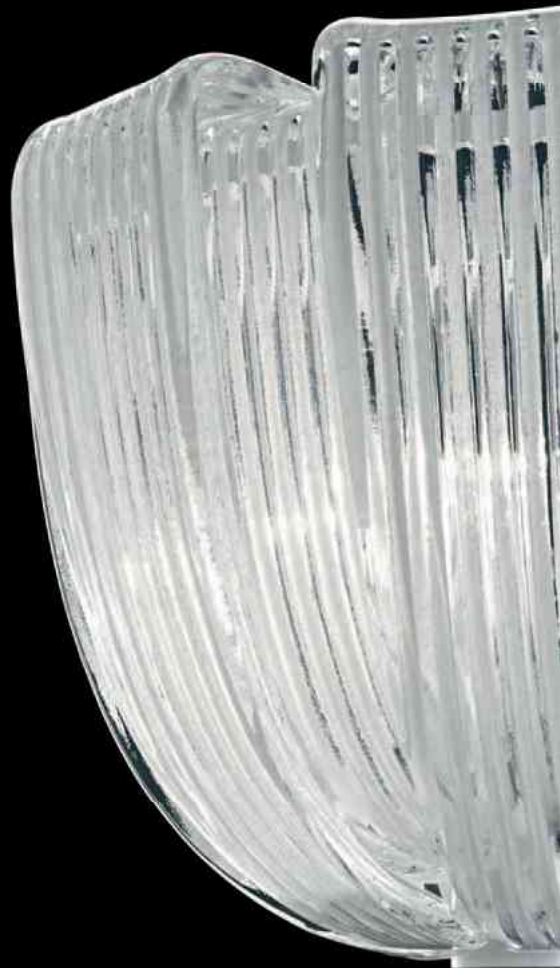
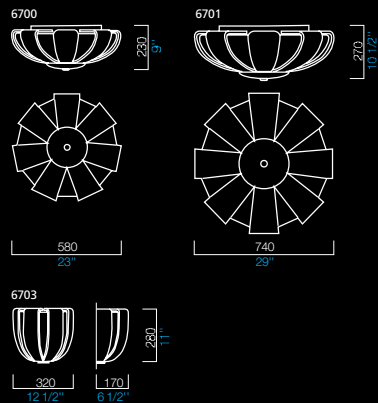

BB  
bianco  
white



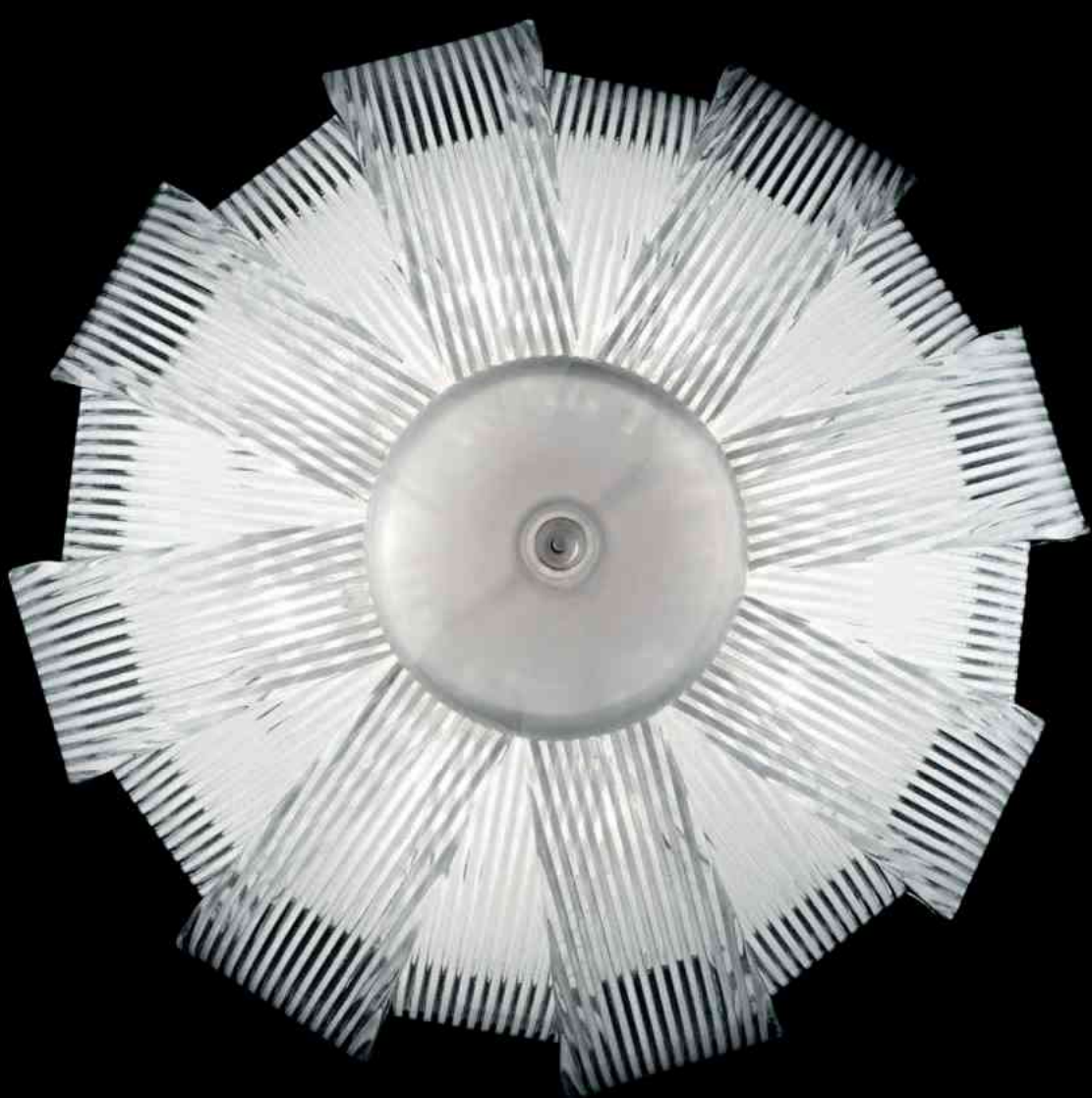

# Titanic

5515

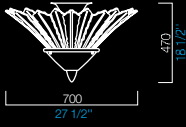

5516



5514

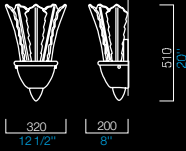

66

CC  
cristallo satinato/cromo  
satinized crystal/chrome



CR  
cristallo satinato/rame  
satinized crystal/copper



GO  
giallo satinato/ottone  
satinized yellow/brass



GN  
giallo satinato/nichel nero  
satinized yellow/black nickel





# Fontana

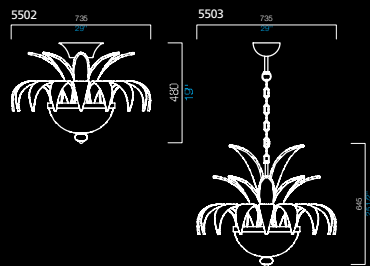

70

CC  
cristallo  
crystal

VC  
verde/cristallo  
green/crystal





## Fanale 1930

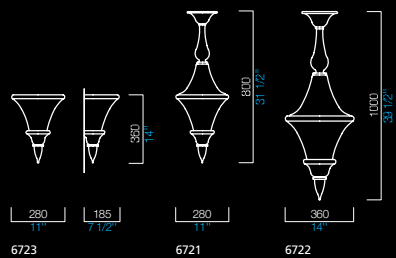





# Primavera

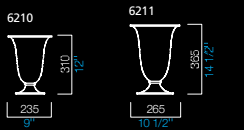
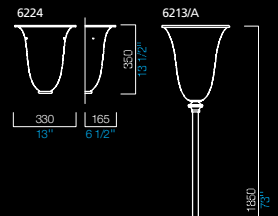
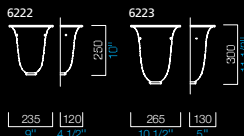
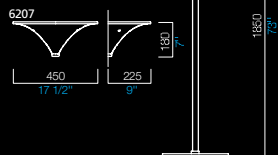
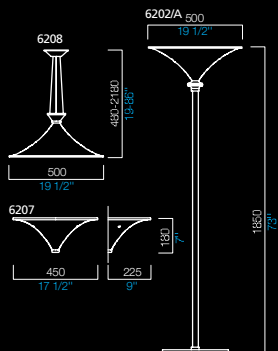

78

BN  
bianco/decoro nero oro  
white/black gold decorations





# Impero

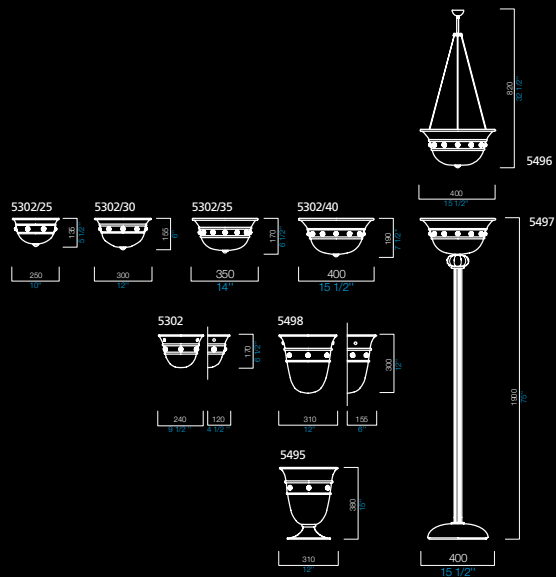

82

OR  
beige oro  
beige gold

PO  
perlaceo oro  
pearly gold





### Caratteristiche dei prodotti

Le descrizioni e le illustrazioni del presente catalogo si intendono fornite a titolo indicativo e non impegnativo. Barovier&Toso si riserva il diritto, ferme restando le caratteristiche essenziali dei prodotti qui descritti ed illustrati, di apportare alle proprie collezioni, in qualunque momento e senza avviso, le eventuali modifiche di parti, dettagli e accessori che essa ritenesse opportune.

### Marchio registrato

Barovier&Toso è un marchio registrato in tutto il mondo.

### Avviso importante

Barovier&Toso non risponde per eventuali danni a persone o cose causati da una non corretta installazione dei propri apparecchi di illuminazione, da un uso di lampadine diverse da quelle prescritte o dalla modifica delle caratteristiche tecnico-costruttive dei prodotti stessi.

### Istruzioni per il montaggio e controllo di qualità

Ogni prodotto è fornito di un apposito dossier contenente tra l'altro il certificato di autenticità e la scheda di collaudo e montaggio. Sulla scheda è indicata la data al confezionamento del prodotto e le sigle di identificazione degli addetti al controllo di qualità. In caso di reclamo, il cliente dovrà sempre fornire copia della scheda. La scheda, inoltre, fornisce tutte le istruzioni per un corretto montaggio della lampada.

### Omologazioni

Tutti i nostri lampadari sono omologati



### Copyright

Il materiale riportato in questo catalogo e il catalogo stesso sono tutelati dalle leggi sui diritti relativi al copyright, ai marchi commerciali e/o su altri diritti di proprietà intellettuale. Detto materiale è di proprietà di Barovier&Toso Vetriere Artistiche Riunite srl o delle sue controllate o consociate. Il suddetto materiale comprende, a titolo meramente esemplificativo, fotografie, immagini, illustrazioni, testo, disegni, logo, marchi commerciali, veste commerciale ed eventuale altro materiale contenuto nel catalogo. Tutti i diritti riservati.

È vietata la registrazione, memorizzazione, moltiplicazione in copie, riproduzione, ulteriore pubblicazione, esposizione, esibizione, trasmissione, distribuzione, trasferimento, traduzione, trasposizione, modifica, anche parziale, di tali contenuti (consistano essi in informazioni, grafica, testi, immagini e qualsiasi altra espressione creativa) in qualsiasi forma e con qualsiasi mezzo (elettronico, meccanico, telematico, a mezzo di fotocopie, stampe, microfilm, registrazioni su qualsiasi supporto), salvo preventiva e specifica autorizzazione da parte di Barovier&Toso Vetriere Artistiche Riunite srl.

Qualora venga concessa la preventiva autorizzazione scritta alla riproduzione, è fatto comunque obbligo di citarne la fonte.

### Main features of the products

Specifications and pictures contained in this catalogue are indicative but not binding. Therefore, while keeping the main features of the above described models, Barovier&Toso reserves the rights to modify parts, details and fittings of its collection range whenever it deems it necessary, without previous notice to its customers.

### Registered trade-mark

Barovier&Toso is a registered trade-mark all over the world.

### Important notice

Barovier&Toso is not liable for injuries or damages due to incorrect installation of its fixtures, use of bulbs different from those prescribed, modification of the original constructional or technical characteristics of the items.

### Installation instructions and quality test

Each item is accompanied by its own "dossier" including a certificate of authenticity and a card containing quality control inspections and installation instructions. This card shows both the packing date and the identification marks of the inspectors. In case of complaint, the customer should send us a copy of this card, which also contains instructions for correct assembly of the fixture.

### Certifications

All our items comply with the standard of



### Copyright notice

All materials on this catalogue and the catalogue itself, are protected by copyrights, trademarks and/or other intellectual property rights. These materials are owned by Barovier&Toso Vetriere Artistiche Riunite srl or its subsidiaries or affiliates. Such materials include, but are not limited to, the photographs, images, illustrations, text, designs, logos, trademarks and other materials contained in this catalogue. All rights are reserved, worldwide.

























You may not record, store, copy, reproduce, republish, publicly exhibit, post, transmit, distribute, transfer, translate, transcribe, modify, in whole or in part, any such material (information, artwork, text, pictures and the like), in any form or by any electronic, mechanical, photocopying, recording or any other means (including CD-ROM) without first obtaining the case-by-case prior consent of Barovier&Toso Vetriere Artistiche Riunite srl.

When the reproduction has been previously authorized, the use is permitted only if the source for the material has been clearly stated.

### Dati tecnici

#### Technical notes

-  Lampada da tavolo  
Table lamp
-  Lampada da terra  
Floor lamp
-  Lampada da parete  
Wall sconce
-  Plafoniera  
Ceiling lamp
-  Sospensione  
Suspension lamp
-  Lampadario  
Chandelier

-  GX 5.3 12V
-  GX 5.3 12V
-  G 53 alogena 12V
-  G 53 halogen 12V
-  GU10 alogena
-  GU10 halogen
-  R7 alogena
-  R7 halogen
-  E14 alogena
-  E12 halogen
-  E27 alogena
-  E26 halogen
-  E14 incandescenza
-  E12 incandescent
-  E27 incandescenza
-  E26 incandescent
-  E27 fluorescente
-  E26 fluorescent
-  Led
-  Led
-  R75-15 alogena
-  R75-15 halogen
-  12 v
-  12 v

### Finiture metalliche

#### Metal fixtures



OL ottone lucido  
polished brass



VR verniciato oro  
painted gold

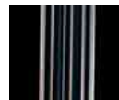

CL cromo lucido  
polished chrome



VG verniciato grigio  
painted grey



OB ottone brunito  
bronzed brass



RA rame  
copper



CN cromo nero  
dark chrome





**Barovier&Toso**

Vetriere Artistiche Riunite srl a socio unico  
Fondamenta Vetrai 28  
30141 Murano  
Venezia  
T (+39) 041739049  
F (+39) 0415274385  
barovier@barovier.com  
www.barovier.com

Showroom  
Milano - Galleria Manzoni 40  
Murano - Fondamenta Vetrai 28

franco raggi  
marco strina  
marco magoga - studio pointer  
pluscolor  
grafiche sz - verona

direzione artistica  
progetto grafico  
foto  
prestampa  
stampa  
giugno 2008

massimo bovi  
sara pedralli

coordinamento  
ufficio tecnico



Barovier&Toso®